



Planning guide for escalators and moving walks

The best solution requires step-by-step
preparation.



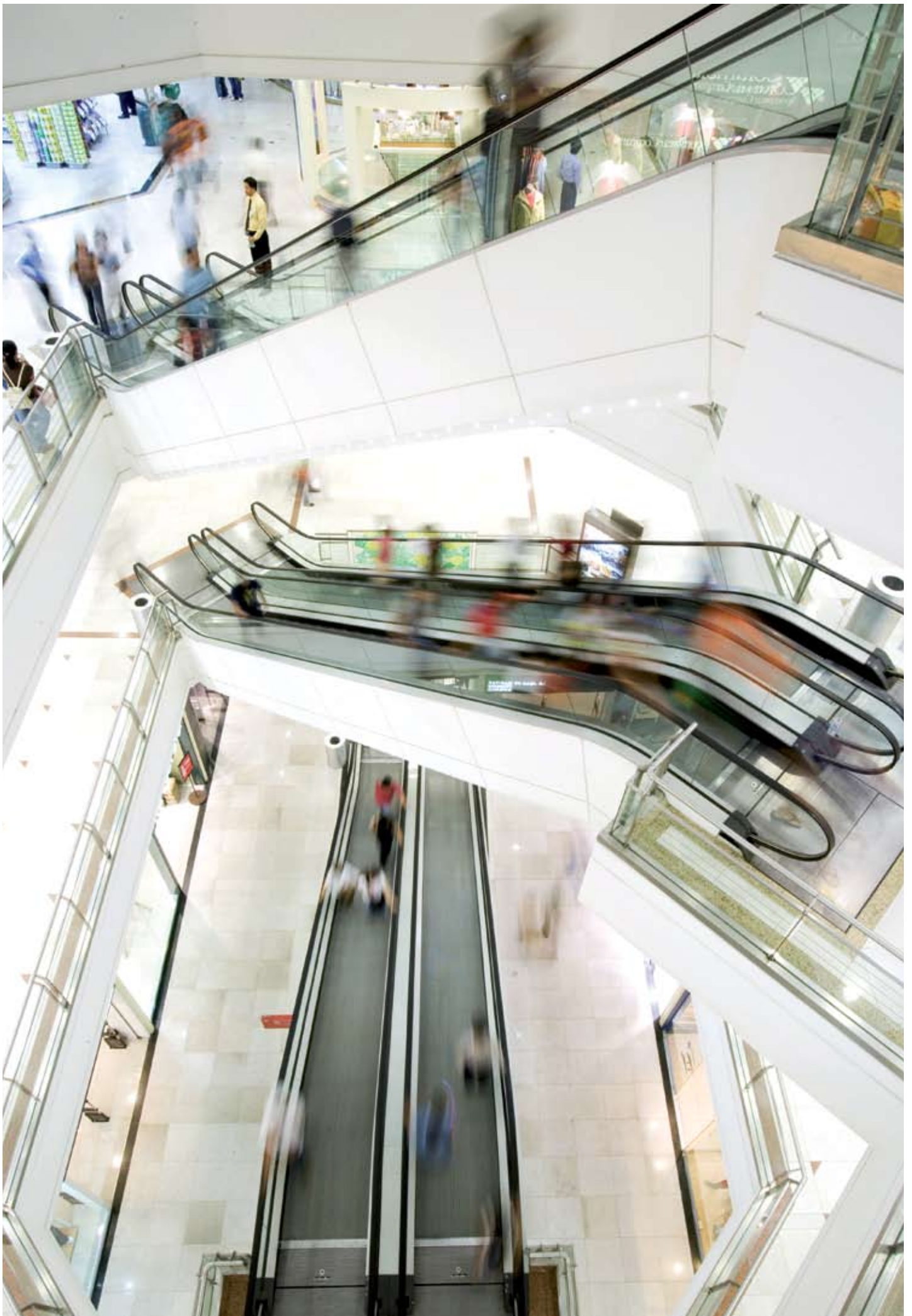

Table of contents

Introduction	4
Why escalators and moving walks matter	5
- Commercial sector	
- Public sector	
- Escalators, moving walks and elevators	
Basic planning	7
- Positioning escalators or moving walks within a building	
- Escalators or moving walks?	
- How many escalators or moving walks?	
- Arrangement of escalators and moving walks	
- Proper inclination	
- Optimal step, pallet and rubber band widths	
- Optimal speed	
Detailed planning	14
- Standards	
- Transportation of disabled persons, transportation of baby carriages	
- Space requirement	
- Safety, regulation-compliant	
- Operating modes	
- Special applications	
The best product for your premises	21
Services provided by the customer, site preparations	23
- Introduction of the escalator or moving walk into the building	
- Transportation to the installation site	
- Delivery modes	
- Suspension points to be provided by the customer	
- Connections to other installations	
From production release to final installation	27
- Production release	
- Site preparation inspection	
- Transportation from factory to site	
- Introduction into the building	
- Setting down onto the end supports	
- Final installation, commissioning	
Interactive configuration with SchindlerDraw	30
Key points for the planning process – a checklist	31

Introduction

No invention has had more of an influence on shopping than the escalator. Over the past 100 years the escalator has opened up a whole new world as a simple means of connecting different floors, a world we now move around in as a matter of course.

The escalator was the most radical element of this process of architectural change, and even today it is still the most popular installation in our retail environment – even if it is the one least perceived by its users.

Escalators and moving walks still play a key role in transporting large numbers of people. Planning escalators and moving walks correctly in shopping centers, trade fair centers, stores, movie theaters and public transportation facilities is essential for the successful course of business and the smooth flow of people. This brochure is your universal guide to all the main process stages, from project planning to commissioning.



Why escalators and moving walks matter

Commercial sector

Escalators and moving walks are used to increase customer density and thus help to boost sales in buildings used for commercial purposes. The following examples taken from everyday practice clearly illustrate how and why:

Example 1: Department store

A six-story department store in the center of a European capital had three elevator units operated by a single control system. The objective here was to boost sales on the upper floors by 20 percent by increasing customer flow.

At the planners' recommendation the owner opted to install escalators. As a result, customer flow was substantially increased and sales rose by more than 30 percent.

Example 2: Food store

A retailer provided access to the upper floor of his store using two comfortable and attractively designed glass elevators. Moving walks had not

been installed for space reasons. Even after the elevators had been in operation for some time, the scheduled sales figures on the upper floor were not achieved due to insufficient customer flow. Once moving walks were installed, sales increased several fold.

Example 3: Underground parking garage

A centrally located department store with a food hall and a multistory underground parking garage was unable to achieve its scheduled turnover objectives in the food hall. Internal analyses showed that elevator access as a whole was insufficient. Using moving walks to provide access to all underground levels solved the problem as customers were able to get to their cars directly with their shopping carts. The sizable investment into the retrofit installation was justified by the increase in sales.

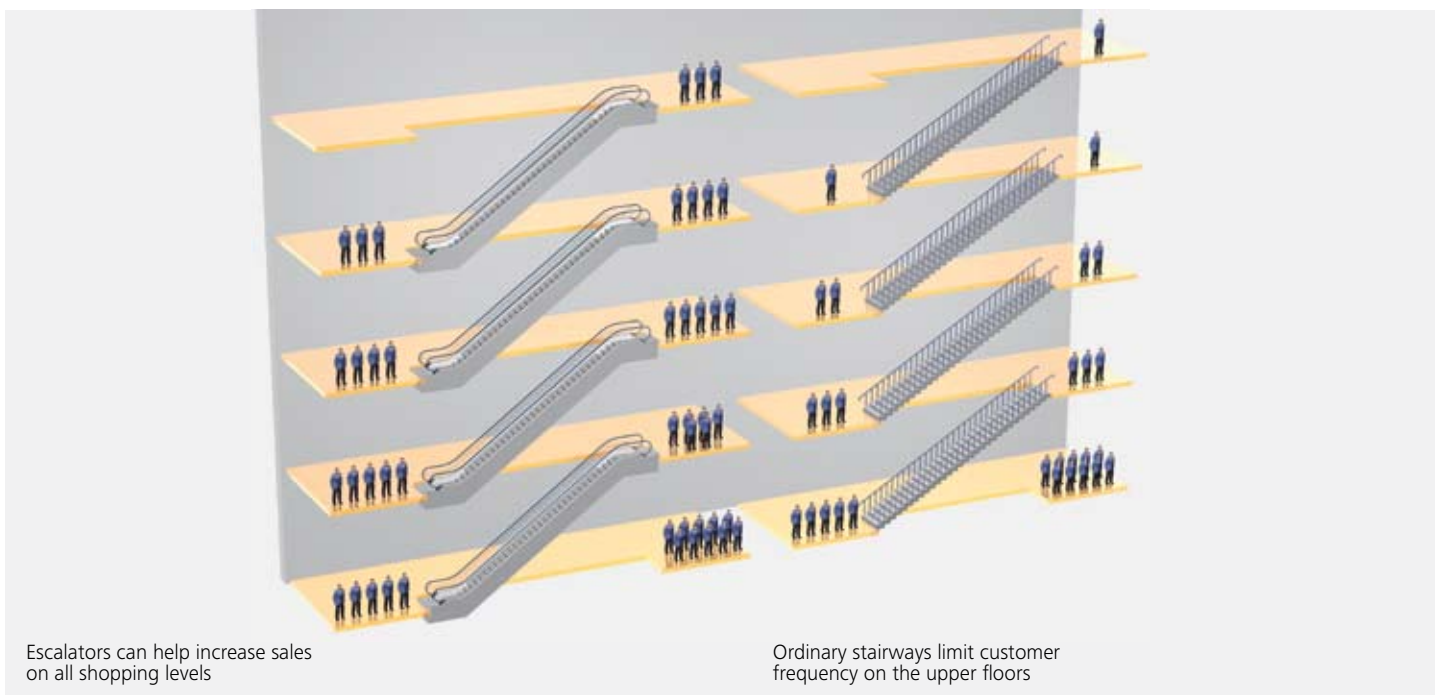

Escalators can help increase sales on all shopping levels

Ordinary stairways limit customer frequency on the upper floors

Why escalators and moving walks matter

Public sector

Transporting large numbers of people efficiently is the top priority in public transportation. Schindler offers customized solutions for this area of application. Our escalator experts can tell you all about the special configuration options.

Escalators, moving walks and elevators

In the commercial sector, escalators and moving walks as well as elevators ensure a smooth traffic flow. Our experts will suggest the right choice and combination to suit your specific requirements.

Advantages of escalators and moving walks:

- Escalators and moving walks with a moving step/pallet band look inviting
- Escalators and moving walks help channel passenger flows
- Escalators and moving walks have a high transportation capacity
- Escalators and moving walks are open and convey people continuously
- Escalators and moving walks ensure that all floors are frequented evenly



Basic planning

Positioning escalators or moving walks within a building

Basically, to achieve optimal customer density, the movement of customers within the building has to be facilitated. Distances in excess of 50 meters should be avoided on commercial premises and in office buildings. The charts below show basic escalator arrangements.

Customer circulation on sales premises depends on different criteria such as the layout of the goods on sale. Fast-selling goods are usually sold in areas that are farther away from escalators. We recommend working closely with specialized store fitters or planners.

Escalators or moving walks?

Moving walks should be provided as a matter of principle whenever shopping or baggage carts are to be transported.

How many escalators or moving walks?

To determine the transportation requirements (persons per hour), you need to consider the following parameters:

- Type of building (offices, shopping center, movie theater, subway station, airport; one-way traffic, two-way traffic; single- or multi-purpose building)
- Peak traffic times (office opening and closing hours)
- Population factor based on net usable area
- Customer turnover rate per floor in department stores
- Level of traveling comfort required on the unit (uncrowded, convenient, crowded)

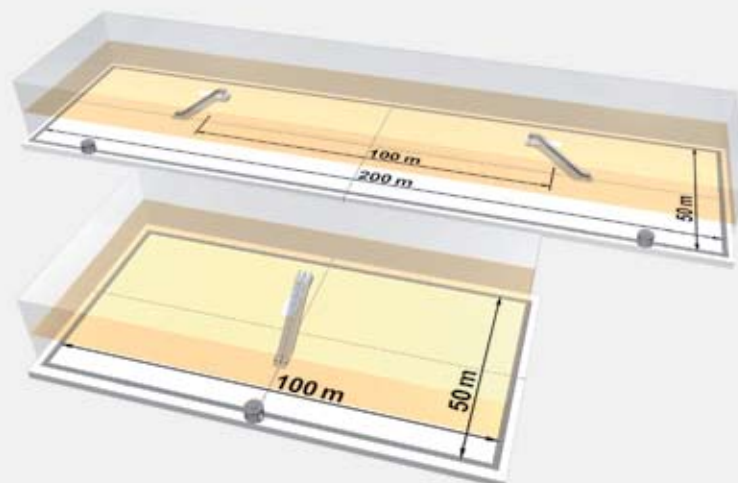

Installation possibilities for escalators or moving walks inside buildings

Basic planning

Once the transportation requirements have been stipulated, you can determine the number of escalators or moving walks required. Our experts will be happy to advise you.

The theoretical transportation capacities depend on the width and speed of the escalators. The effective transportation capacity is between 40 and 80 percent of the theoretical transportation capacity depending on user density and step width. The capacity of moving walks is calculated accordingly, taking into account transportation of shopping and baggage carts.

Arrangement of escalators and moving walks

Single unit

The single unit is used to connect two levels. It is suitable for buildings with passenger traffic flowing mainly in one direction. Flexible adjustment to traffic flow (e.g., up in the morning and down in the evening) is possible.

Continuous arrangement (one-way traffic)

This arrangement is used mainly in smaller department stores to link three sales levels. It requires more space than the interrupted arrangement.

Step width	Theoretical transportation capacity	Effective transportation capacity at a rated speed of			
		v = 0.5 m/s	v = 0.5 m/s uncrowded	v = 0.5 m/s convenient	v = 0.5 m/s crowded
600 mm	4500 pers./h	1800 pers./h	2700 pers./h	3600 pers./h	4400 pers./h
800 mm	6750 pers./h	2400 pers./h	3600 pers./h	4800 pers./h	5850 pers./h
1000 mm	9000 pers./h	3000 pers./h	6750 pers./h	3000 pers./h	7300 pers./h

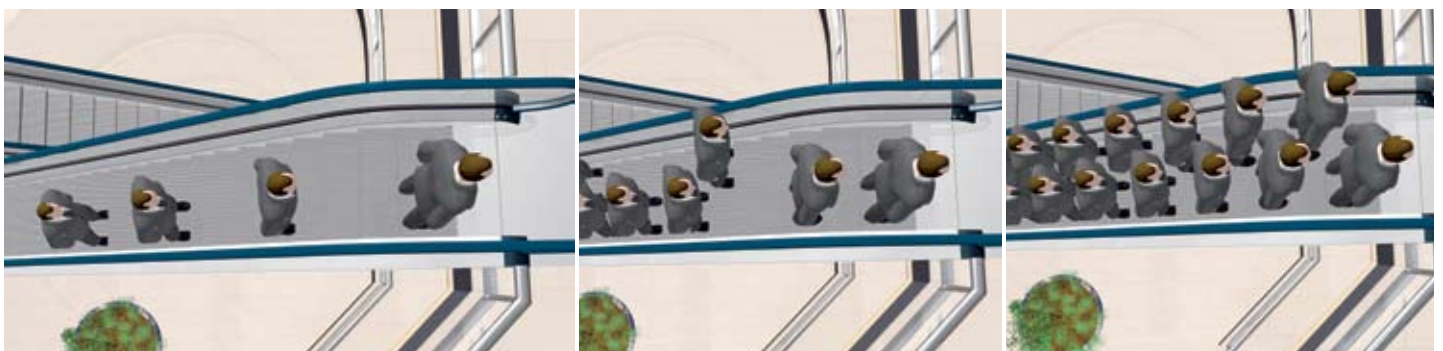

Interrupted arrangement (one-way traffic)

While relatively inconvenient for the user, for the owner of the department store it provides the advantage that due to the spatial separation of the upward and downward directions, customers have to walk past specially placed merchandise displays.

Parallel, interrupted arrangement (two-way traffic)

This arrangement is used mainly in department stores and public transportation buildings with heavy traffic volumes. When there are three or more escalators or moving walks, it should be possible to reverse the direction of travel depending on the traffic flow.

Crisscross, continuous arrangement (two-way traffic)

This type of installation is the one used most frequently as it allows customers to travel quickly to the upper floors without any waiting time. Depending on how the escalators are positioned, the store fitter can open up the view onto the shop floor to stimulate customer interest in the goods on display.

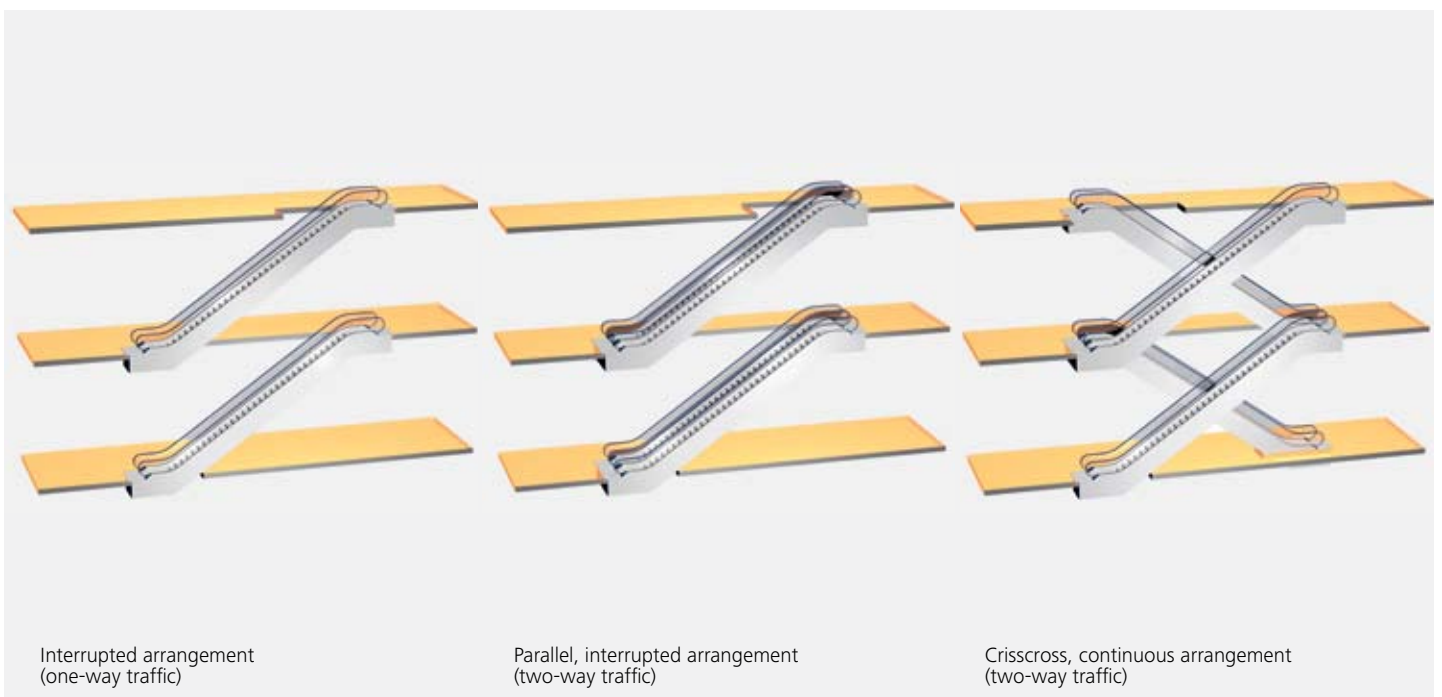

Interrupted arrangement (one-way traffic)

Parallel, interrupted arrangement (two-way traffic)

Crisscross, continuous arrangement (two-way traffic)

Basic planning

Proper inclination

Escalators

Inclinations of 30° and 35° are the common international standard for escalators.

30° inclination

This inclination provides the highest traveling comfort and maximum safety for the user.

35° inclination

The 35° escalator is the most efficient solution as it requires less space and can be implemented more cost-effectively. However, this inclination is perceived as too steep if rises exceed 5 m – particularly in downward travel. According to EN 115, a 35° inclination is not permissible with rises of more than 6 m. This inclination is not permitted in countries that stipulate the US ANSI standard.

Moving walks

Inclinations of 10°, 11° and 12° are the common international standard for inclined moving walks. Users find that a 10° inclination provides the most comfortable ride. A 12° inclination is used whenever the space available is limited.

Horizontal moving walks can generally be provided for inclinations between 0° and 6°.

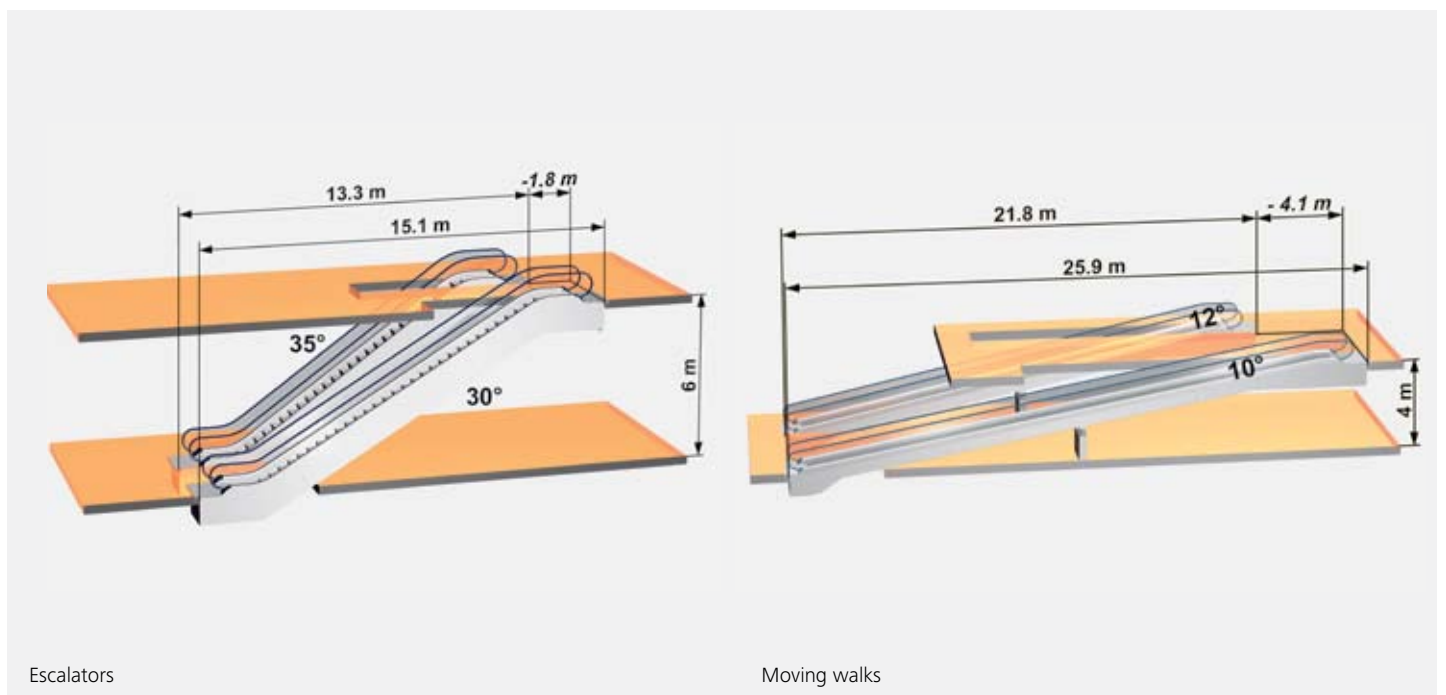

Escalators

Moving walks

Optimal step, pallet and rubber band widths

Escalators

Escalators are available with step widths of 600, 800 and 1000 mm. The most popular step width is 1000 mm. This step width gives the user unimpeded access to the step band, even with baggage and shopping bags. The other two step widths are used mainly for less frequented units or where space is restricted.

Moving walks

For inclined moving walks (10° to 12°) pallets are available in widths of 800 and 1000 mm. The most popular width is 1000 mm. Since moving walks with this pallet width are also suitable for transporting shopping and baggage carts, they are used mainly in shopping centers and railway stations.

A moving walk width of 1000 mm is generally recommended as the pallets should always be 400 mm wider than the shopping carts when moving walks are operated with shopping carts.

For horizontal moving walks with an inclination of 0° to 6°, pallets are available in widths of 800, 1000, 1200 and 1400 mm. At airports, there is an increasing tendency to use 1200 or 1400 mm wide moving walks, since this width easily allows users to step around passengers with baggage carts. Schindler also offers rubber belt moving walks specifically for this purpose. Belts are available in widths of 1000, 1200 and 1400 mm.

If a number of escalators or moving walks are to be installed in a continuous arrangement in a building, the same step, pallet or rubber band width should be selected for all units in order to avoid local congestion.



Basic planning

Optimal speed

Speed not only has a considerable impact on the potential transportation capacity of escalators and moving walks, but it also influences the space requirements. The tables below summarize the different product configurations depending on speed.

0.5 m/s for continuous customer flow

This is the optimal speed for all escalators and moving walks in the commercial sector. The combination of sufficient transportation capacity, optimal safety and minimum space requirement makes this speed the worldwide standard for this application.

Escalators: Table according to EN 115 (other national regulations can be met)

Rise	Speed	Maximum inclination	Horizontal step run (mm)
H ≤ 6 m	≤ 0.5 m/s	35°	800
	> 0.5 ≤ 0.65 m/s	30°	1200
	> 0.65 ≤ 0.75 m/s	30°	1600
H > 6 m	≤ 0.5 m/s	30°	1200
	> 0.5 ≤ 0.65 m/s	30°	1200
	> 0.65 ≤ 0.75 m/s	30°	1600

Moving walks: Table according to EN 115 (other national regulations can be met)

Rise	Speed	Inclination	Horizontal pallet run (mm)
not limited	≤ 0.75 m/s *	0°-6°	not required
by standards		10°-12°	400 at the top
	> 0.75 ≤ 0.9 m/s *	max. 12°	1600 at top and bottom, pallet width ≤ 1.1 m

* v ≤ 0.65 m/s is recommended

0.6 or 0.65 m/s for intermittent transportation requirements

This speed is recommended for intermittent passenger arrivals, as at railway stations or subway stations. It has also proved effective at trade fair centers. Longer horizontal runs and larger transition curves are required at these speeds to guarantee optimal safety and loading factor of the escalator/moving walk.

0.75 m/s for extreme transportation capacity

Although speeds up to 0.75 m/s (escalators) and up to 0.9 m/s (moving walks) are possible, they are not recommended as the effective transportation capacity will not increase any further and there is an increased danger of children or elderly people tripping or falling in the landing areas.

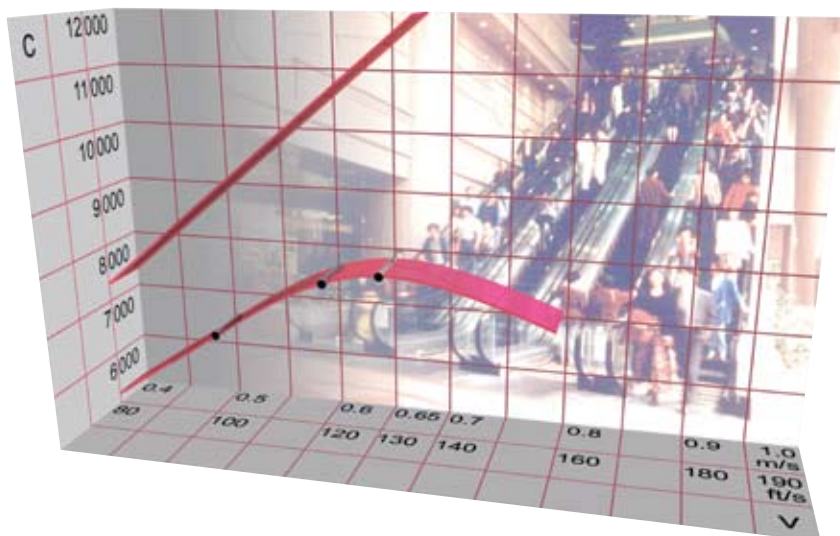

Transportation capacity c (persons/h) as a function of speed

c = theoretical transportation capacity (persons/h) for a nominal width of 1000 mm

c theoretical
 c effective
speed in m/s

Detailed planning

Standards

The European EN 115 standard and the European Machinery Directive (98/37/EC) define and regulate the safe structural design and safe installation of escalators and moving walks in buildings. In North America the standards of the American National Standards Institute (ANSI) have to be observed. The planning instructions in this brochure refer to these regulations.

The standard-compliant inclination and speed have already been discussed under **Proper inclination** and **Optimal speed**.

Transportation of disabled persons, transportation of baby carriages

Escalators and moving walks are **not** suitable for transporting wheelchairs and baby carriages. It is recommended to post a sign in the access area of escalators and moving walks indicating where the nearest elevators are located.

Space requirement

Step and pallet run

The correct number of horizontal steps/pallets in the landing areas (i.e., the so-called step and pallet run) of escalators and inclined moving walks according to EN 115 or ANSI depends on the rise, the inclination and the rated speed. The standard-compliant step and pallet run is indicated in the two tables under **Optimal speed**.

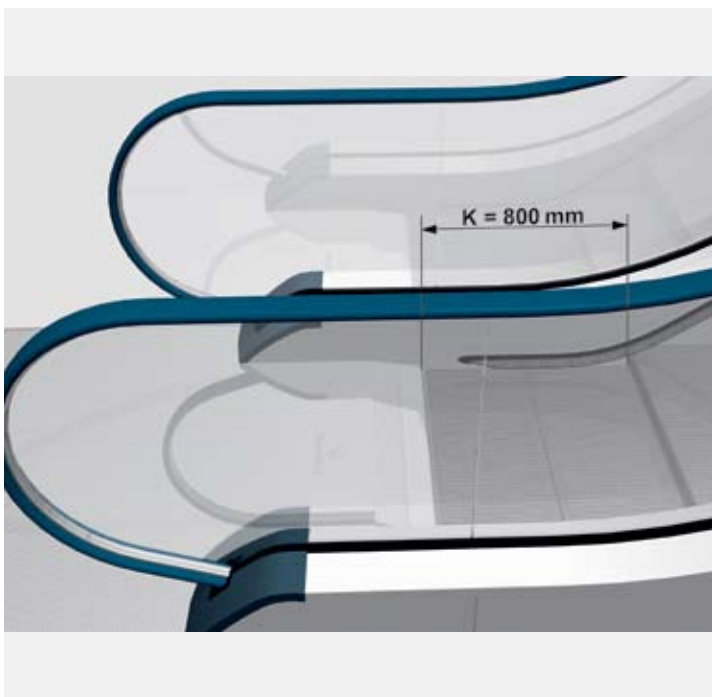

Free spaces

To ensure safe use of the escalators and moving walks, sufficiently large free spaces must be provided at the upper and lower landings (see the figure for minimum dimensions according to EN 115).

For moving walks that are expected to have a high traffic volume and that are also designed for transporting shopping and baggage carts, the free spaces should have a length of at least 5 m. If the carts are pushed into one another when transported on the moving walks, the free spaces are to be adapted accordingly (see also **Moving walk operation with shopping carts**).

Safety, regulation-compliant

Balustrade height

Balustrades are available in heights of 900, 1000 and 1100 mm. The advantage of 900-mm balustrades is that even small children can easily reach the handrail. For greater fall heights we recommend balustrades with a continuous height of 1000 mm. A balustrade height of 1100 mm is also available if required under national regulations.

Overhead clearance

The free overhead clearance at every point along the step/pallet band must be at least 2.3 m. According to ANSI the dimension is 7 ft (2130 mm).

Safety clearances

The horizontal clearance from the outer edge of the handrail to the walls or other obstacles must always be at least 80 mm. This clearance must be maintained up to a height of at least 2.1 m above the step/pallet band. With vertical walls, all Schindler escalators and moving walks provide the specified safety clearance of 80 mm.

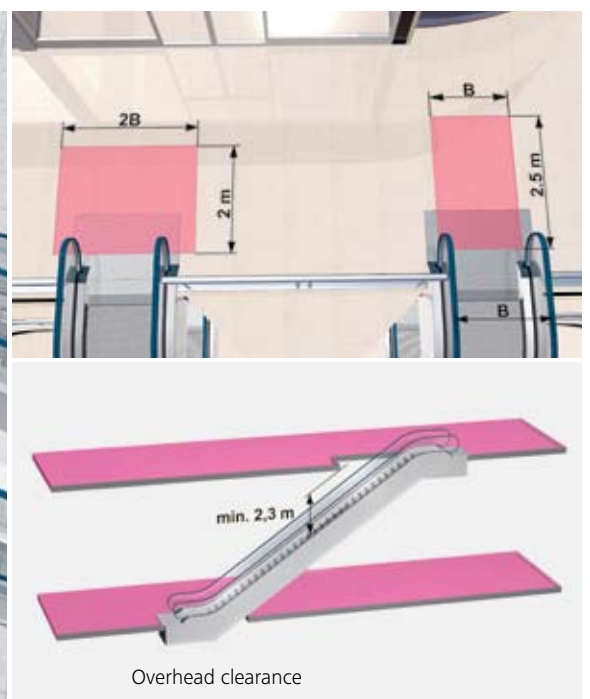
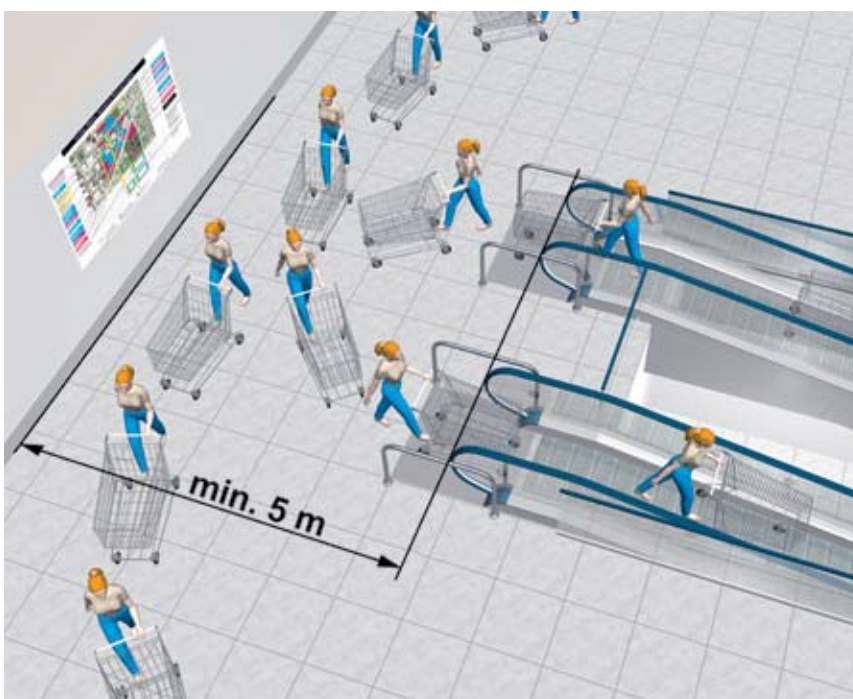

Detailed planning

In the case of floor openings and escalators or moving walks arranged in a crisscross pattern, the horizontal distance from the center of the handrail to the obstacle must be at least 0.5 m. If the distances are shorter, the wall must be even and have no projecting features. Special guards and deflectors are required if this safety clearance is not met.

According to ANSI, a distance of 102 mm has to be observed between handrail and adjacent surfaces.

Protective barriers, ceiling deflectors, wedging guards

With escalators and moving walks arranged in a crisscross pattern or with floor openings, there is a risk of wedging between balustrades and adjacent escalator/moving walk bodies or ceilings and columns. If the distance between the center of the handrail and the obstacle is less than 0.5 m, wedging guards or ceiling deflectors are to be provided by the customers.

Appropriate structural measures must be installed to prevent people from accessing escalators or moving walks from the side. Protective barriers and guards should be provided on the balustrades where necessary.

Protective barriers, guards against climbing the balustrades, ceiling deflectors and wedging guards can also be supplied by Schindler as an option.

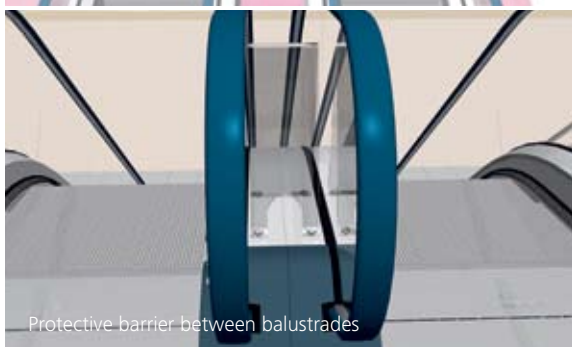
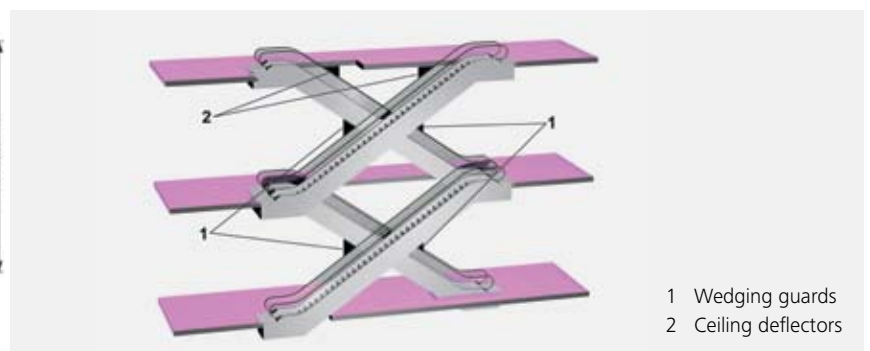
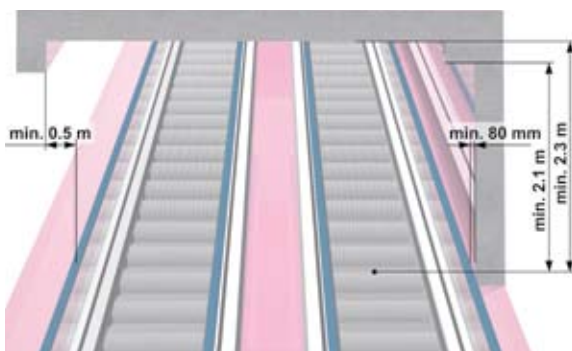

Protective barrier between balustrades



Wedging guard



Guards against climbing the balustrades

Railings provided by the customer

Railings are to be fitted by the customer at the accesses to the escalators and moving walks. The distance to the handrail of the escalator/moving walk must be at least 80 mm. It is recommended to provide the support for the escalator/moving walk at least 1000 mm away from the ceiling edge, so that the balustrade does not have to be extended (see figure).

Operating modes

The operating mode used for the escalators/moving walks can be adapted to their applications. There are essentially three operating modes:

- continuous operation,
- stop-&-go operation, and
- continuous operation with crawling.

Schindler escalators and moving walks offer optimized energy-saving packages for all three operating modes.

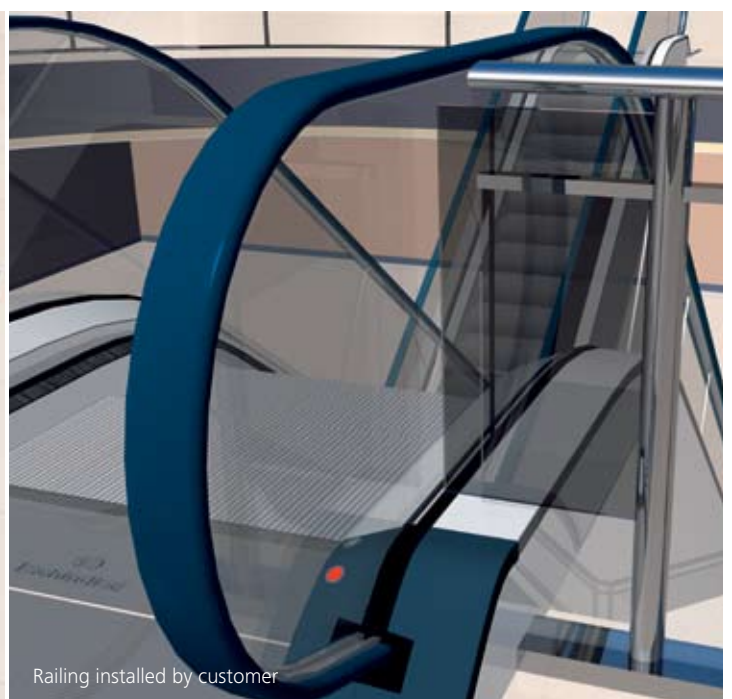
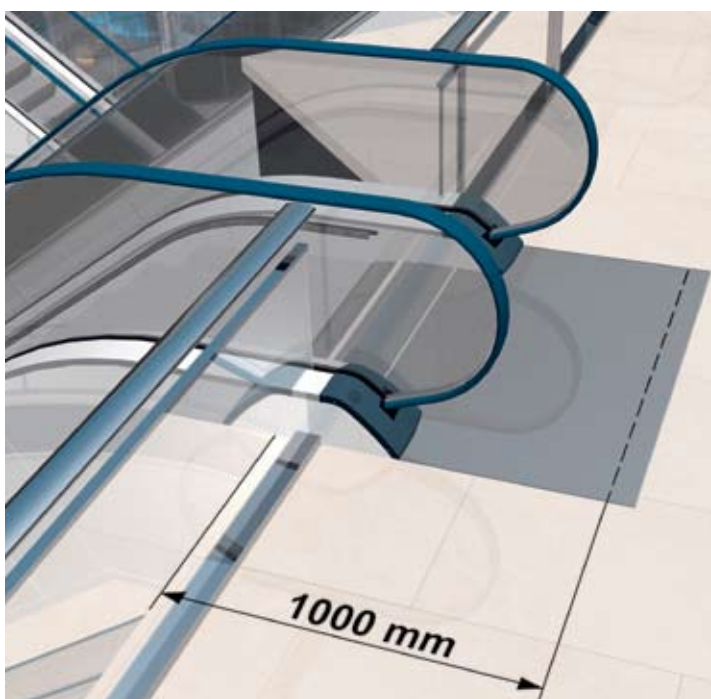

Detailed planning

ECOLINE Competence

Continuous operation is the optimal mode for the commercial sector in which customers are to be transported efficiently to the upper floors of the store.

ECOLINE Plus

Stop-&-go operation is recommended for the intermittent arrival of passengers or for sporadic use outside peak times. Typical applications include movie theaters, airports, subway stations and railway stations. The unit remains ready for operation when there are no passengers, as signaled by a direction indicator. The Schindler entrance monitoring system detects approaching passengers and sets the escalator/moving walk into motion whenever required.

ECOLINE Premium

In *continuous operation with crawling* the escalator/moving walk continues to crawl along at 0.1 m/s in the absence of passengers, using a frequency converter. Unlike conventional stop-&-go operation, mechanical wear is considerably lower, and in this operating mode the readiness for operation and the direction of travel are indicated by the slowly moving steps.

ECOLINE Competence

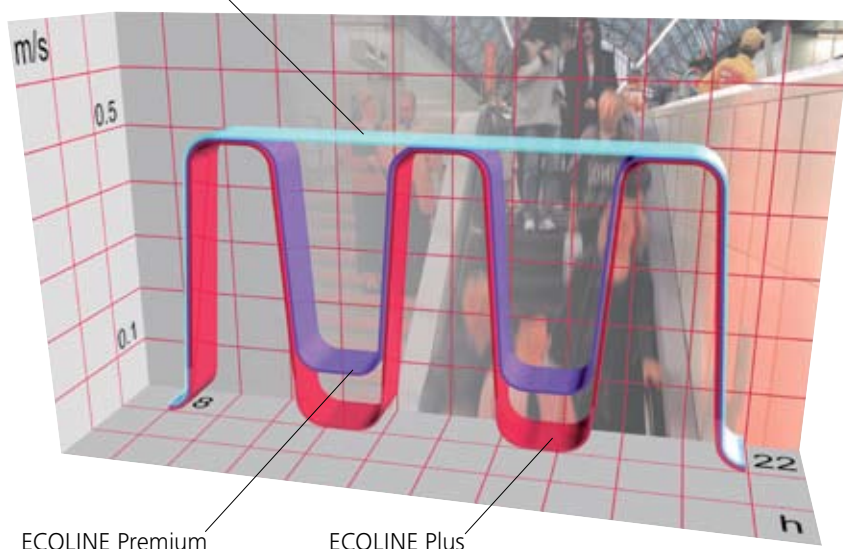

Special applications

Outdoor installation

Special measures are required for escalators and moving walks that are installed outdoors and are therefore subject to the effects of weather conditions. These measures are necessary to achieve optimal unit availability and the longest possible service life for the components. For more detailed information, please contact our experts.

Extreme locations

For applications that require sturdiness and safety under extreme transportation conditions, we recommend our balustrade design I. This inclined balustrade, which is made of 12 mm thick, shock-resistant stainless-steel sandwich panels, provides optimal operation in ski resorts, outdoor applications or in regions susceptible to vandalism.

Moving walk operation with shopping carts

Moving walk width

In an emergency situation, it must be possible to leave moving walks without danger, for example if a moving walk comes to a standstill when an emergency stop button is activated. In order to allow passengers to leave the moving walk in such cases, there must be a minimum distance of 200 mm on one side between the inner side of the balustrade skirting and the part of the shopping cart that protrudes the farthest. This means that the pallets must be at least 400 mm wider than the shopping cart.



Detailed planning

Construction considerations

Ample free space must be provided at the upper and lower landings of the moving walk. The 2.5 m depth of unrestricted space required by EN 115 for the exclusive transportation of passengers must be doubled to at least 5 m for moving walks on which shopping carts are also transported.

Main aisles running perpendicularly to the moving walk may not come to an end in the immediate vicinity of the moving walk. The traffic route leading to the moving walk must be laid out in such a way that it approaches the moving walk in the same direction as the moving walk is traveling. This will assure that the locking devices of the shopping cart wheels specially designed for moving walks will be positioned in the direction of travel when the passenger gets onto the moving walk, and that they will engage in the grooves of the pallets without difficulty. The shopping cart manufacturer is responsible for providing shopping carts of suitable

quality (e.g., DIN 32601, Part 2), and for ensuring that they can be properly blocked by means of an appropriate locking device or brake as well as properly aligned within the pallet grooves during transportation.

Pictographs for the correct use of shopping carts are to be affixed to the upper and lower landings by the shopping cart manufacturer.

Escalator operation with shopping or baggage carts

For safety reasons the transportation of shopping and baggage carts on escalators is not allowed. If transportation is unavoidable, moving walks must be installed.

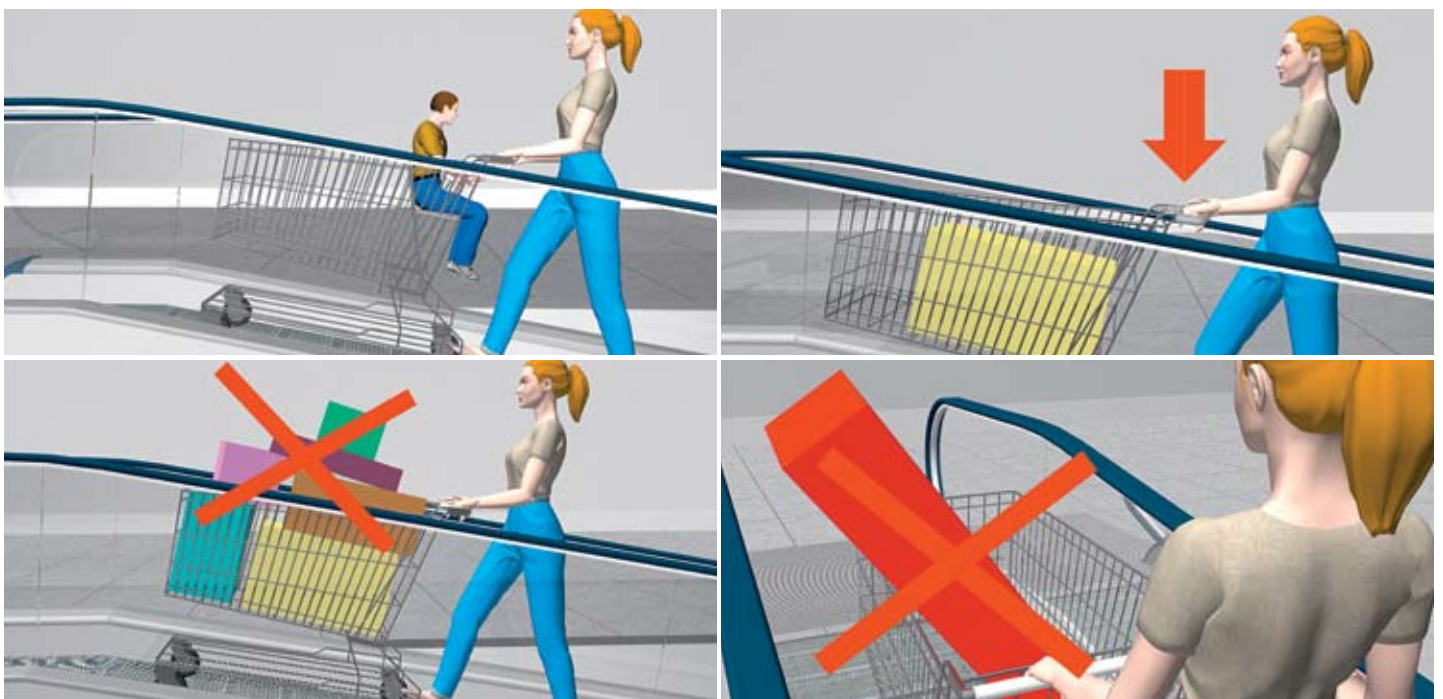

The best product for your premises

Schindler escalators and moving walks are ideally adapted for use in all the relevant application segments. The modular structure of Schindler escalators and moving walks means that the components required can be adapted to each application while retaining the same outer design.

The following table provides an overview of the product types and their main application segments.

	Escalators		Moving walks	
	Schindler 9300 Advanced Edition	Schindler 9700	Schindler 9500	
	Standard	Custom	Inclined moving walk	Horizontal moving walk
Shopping center	X	X	X	
Store	X			
DIY store, supermarket	X		X	
Hotel, office building	X	X		
Movie theater	X	X		
Museum	X	X		
Library	X	X	X	
Trade fair center		X	X	X
Airport		X		X
Railway/subway station		X	X	X



The best product for your premises

Schindler 9300 Advanced Edition

With its individual configuration packages the Schindler 9300 Advanced Edition offers a process-optimized solution to your requirements:

The Schindler 9300 Advanced Edition Standard comprises the variants and option packages most often specified for escalators in department stores and the retail sector. This configuration is standardized throughout, which allows an optimal price-performance ratio.

With the Schindler 9300AE Custom escalator there are virtually no limits to what you can do. Special customized solutions can be configured for rises of up to 13 m.

The Schindler 9300 AE Custom escalator also fulfills the special requirements and specifications of the public transportation sector. The technical equipment featured by this range of products complies with all the requirements in this segment, combining them with the highest levels of aesthetic design.

Schindler 9700

The sturdy design of this product line is aimed at large rises and the special requirements of public transportation. Our experts will gladly advise you.

Schindler 9500

Schindler offers the world's most complete range of products available in the global moving walk market. Inclined moving walks with widths of up to 1000 mm are designed to be used with shopping carts. With widths of up to 1400 mm, horizontal moving walks – with a transportation belt made of aluminum pallets or whisper-quiet rubber with steel inserts – cover perfectly the public transportation requirements at airports, trade fair centers or other facilities.

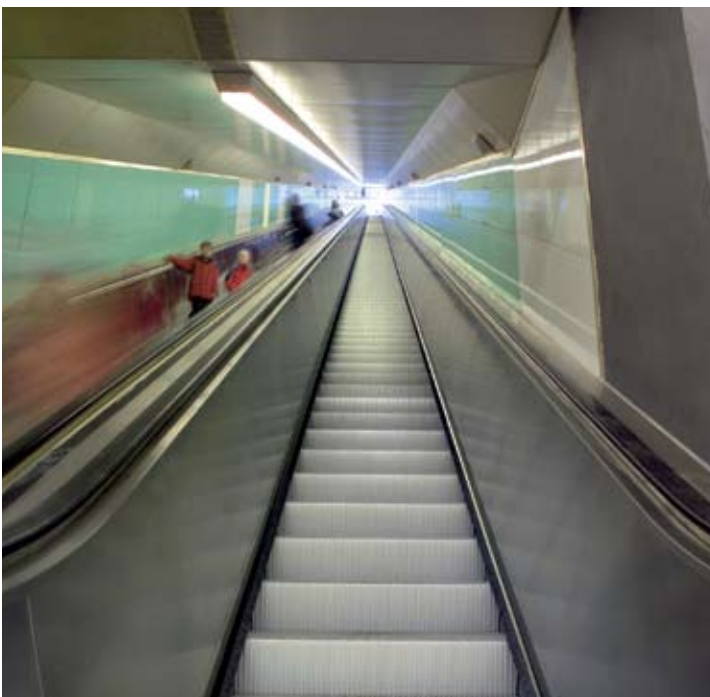

Services provided by the customer, site preparations

Optimal planning and preparation of on-site transportation and introduction of the escalator/moving walk into the building are essential for ensuring the best possible installation sequence and thereby minimizing building costs. Escalators/moving walks are entirely preassembled at the factory. This is why planning on-site transportation of the escalators/moving walks, which can be up to 17 m long and weigh up to 100 kN, is such a key step in the planning process.

Planning is based on the technical specifications on our dimension sheets or on the layout drawing specific to the project.

As a matter of principle, we recommend that you coordinate the date and time as well as the type of introduction into the building and the access route with our experts IN GOOD TIME.

The key points involved in this process are summarized below.

Introduction of the escalator or moving walk into the building

A suitable area for unloading the escalator/moving walk from the truck has to be provided in front of the building. The access routes to the building and the installation site must be level and accessible with roller dollies.

Essentially there are two possibilities of introduction into the building:

- Introduction through ground-floor openings in the building using special forklift trucks
- Introduction by on-site or mobile crane through the appropriate side openings in the building or roof



Services provided by the customer, site preparations

Transportation to the installation site

The clearance over the entire access route must not be less than the minimum dimension stipulated in the dimension sheet/layout drawing. (Don't forget suspended pipes or lines!)

The type of delivery has to be stipulated at the time of the release for production. After that date the escalators/moving walks can no longer be designed in several parts.

The required entrance width depends on the width of the escalator/moving walk. Given the length of the escalator/moving walk, make sure all curves and bends can be negotiated easily. We recommend that you plot out the entire transportation route on a CAD plan or paper model.

The entire transportation route must be level and free of obstacles, and withstand particular floor loads. If not, the appropriate load distribution has to be provided. Our experts can advise you.



Delivery modes

The escalator/moving walk is usually ordered fully assembled, in one part.

If there is insufficient clearance, the escalator/moving walk can be supplied with the balustrades not mounted.

With long escalators/moving walks or restricted space conditions, the escalator/moving walk can be delivered in two or more parts. However, due to the increased transportation and assembly costs this form of delivery should be used only where unavoidable.

Recess clearances, floor openings, supports

Please refer to our dimension sheets and the project-specific layout drawing for all the necessary recess clearances, floor openings and supports.

Suspension points to be provided by the customer

Suspension points for pulley blocks for the proper escalator/moving walk introduction and placement are to be provided by the customer. The suspension points must be positioned along the symmetry axis of the escalator/moving walk above the end supports and – where applicable – the intermediate supports. The exact position is indicated on our layout drawings. The suspension points must be rated for a load of 50 kN.

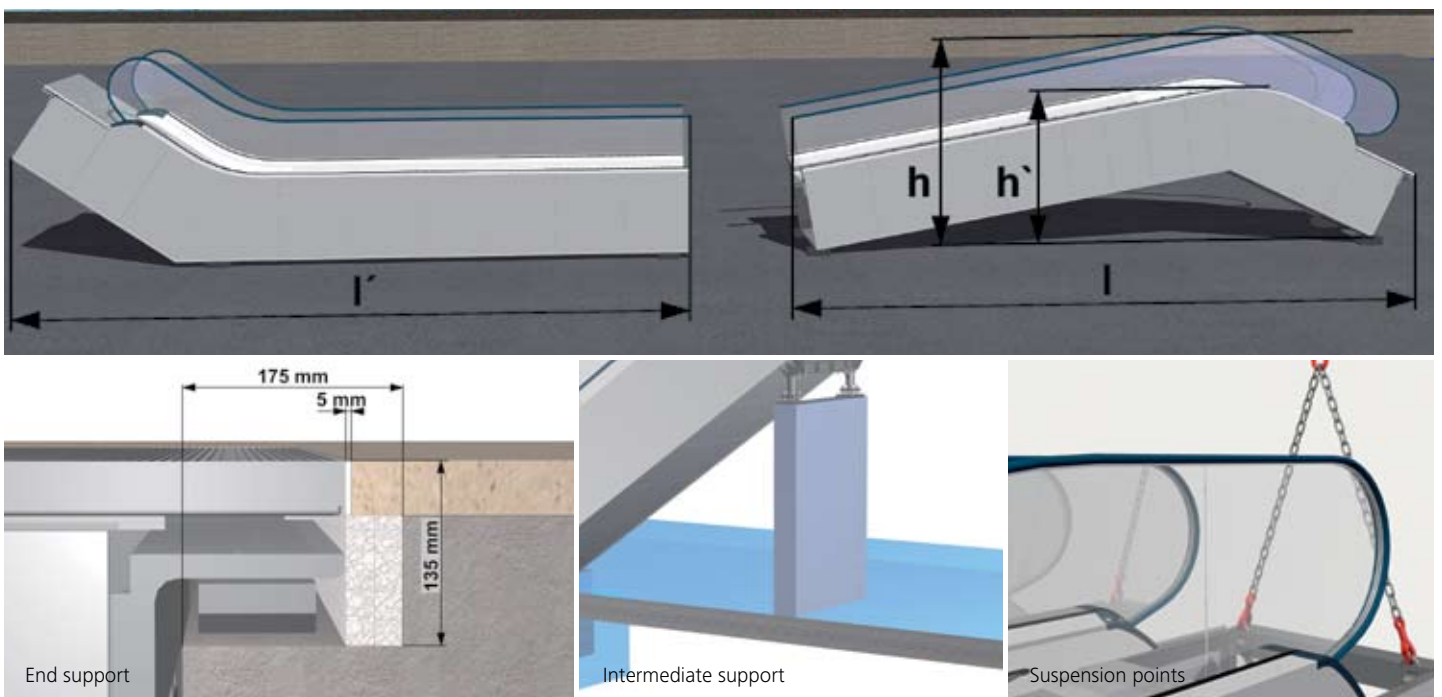

Services provided by the customer, site preparations

Connections to other installations

Electrical connections

The electrical connection is made in principle at the upper escalator/moving walk station as shown in the figure. The number and minimum cross-section of the connecting cables are specified in our layout drawing. The supply connection is to be provided by the customer through an authorized electrician.

Sprinklers

If required by the customer, a sprinkler tubing can be fitted to the escalator/moving walk as an option. The installation of the sprinkler heads and the connection of the sprinkler tubing are to be provided by the customer through an authorized specialist.

Fire control system

The applicable national regulations for commissioning fire control systems must be observed.

Oil separator

An oil separator has to be fitted when installing escalators/moving walks outdoors. If the oil separator is supplied by Schindler (as an option), a recess in the escalator/moving walk pit and a water drain are to be provided by the customer.

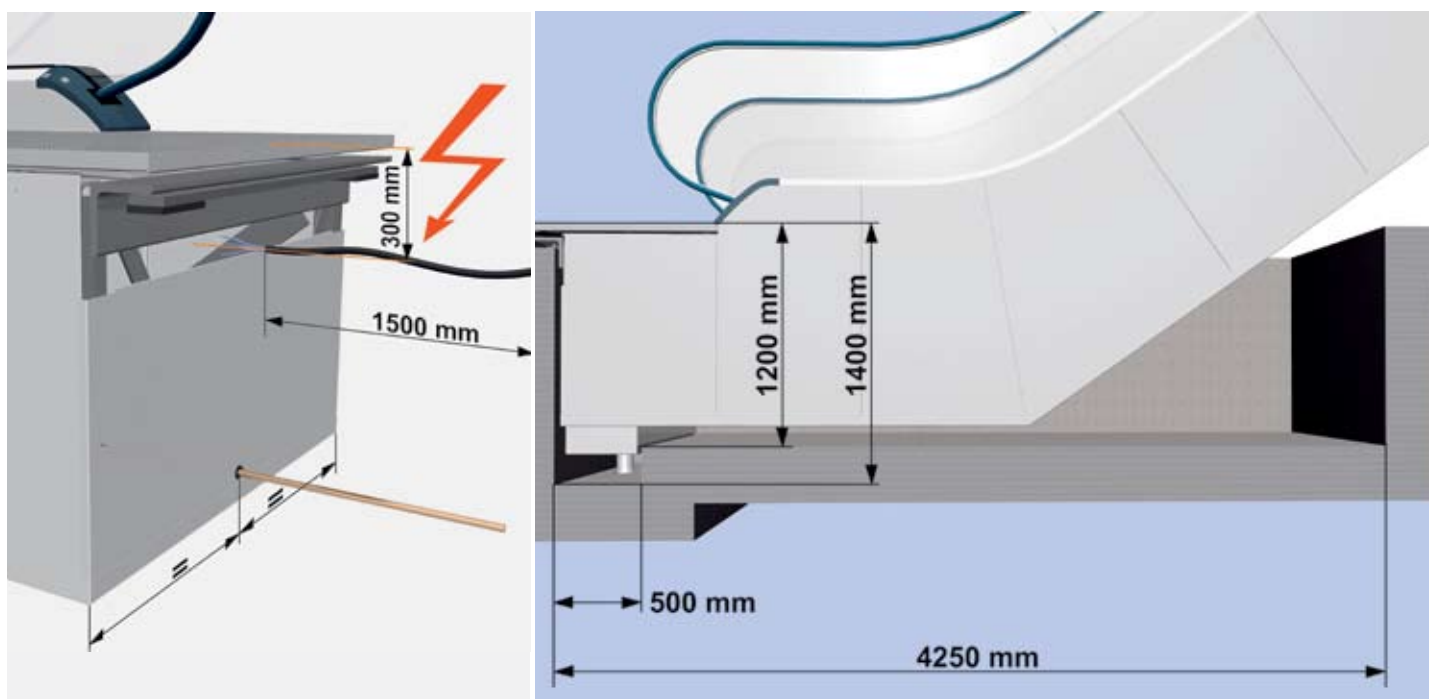

From production release to final installation

Once the detailed planning is completed, you will obtain from us a project planning sheet or a layout drawing based on your indications and containing all the relevant information such as escalator/moving walk geometry, support loads and key electrical data. You can also draw up this plan yourself using SchindlerDraw at www.schindler.com.

Production release

Next, give the go-ahead for the production of the escalator/moving walk by signing the valid project planning sheet or the layout drawing and returning it to us. Check once again that the main dimensions of the escalator/moving walk correspond with the dimensions of your building structure. Our installation team will be happy to coordinate the access route as well as the introduction and placement logistics with you once again.

Site preparation inspection

Before your escalator/moving walk is delivered, our installation team examines on site the supports and the installation dimensions. Acceptance of the preparations to be made by the customer, i.e., electrical connections, transportation routes, etc., is also carried out with the site management.

Transportation from factory to site

Depending on the delivery mode the escalators/moving walks are delivered by truck (or in a container for deliveries overseas). Given the possible excess lengths and heights, official approvals may be necessary for the transportation to the site.



From production release to final installation

Introduction into the building

The introduction into the building up to the supports is a critical process that requires meticulous preparations (see **Services provided by the customer, site preparations**).

Once the escalator/moving walk has been unloaded by crane or forklift truck, the escalator/moving walk is placed on roller dollies and towed by forklift truck. To minimize the on-site transportation logistics, it is extremely important to keep the transportation route as short and as straight as possible.

Setting down onto the end supports

Usually, suspension points in the form of ceiling plates or ceiling openings with a diameter of 50 mm are prepared by the customer in accordance with the indications on the layout drawing to secure the hoisting gear. These points are used to hoist the escalators/moving walks and set them down onto the supports. Each suspension point must have a load-bearing capacity of at least 50 kN.

If no suspension points are provided by the customer, installation scaffolds are used. This installation method takes longer and involves more materials.

If the roof or ceiling opening is sufficiently large, the escalator/moving walk can be set down onto its end supports from above by using a crane.

Because a certain amount of time will probably elapse between the placing of the escalator/moving walk and its commissioning, the unit should be adequately protected against dirt and damage due to building work.



The covering fitted by Schindler should be removed only during commissioning. The escalator is not to be used as a fixed stairway during the construction phase (increased risk of dirt, soiling and damage).

Any dirt that can no longer be removed can affect the service life of mechanical and electrical components.

Final installation, commissioning

Upon completion of installation, the escalator/ moving walk is thoroughly checked once more during a test run. At the handover, you will be given the customer documentation and the keys for the unit.

In some countries acceptance by an authorized verification body is necessary prior to commissioning. The commissioning can then proceed as usual.

Please note that the unit has to be kept in a safe operating state by an authorized maintenance organization. We at Schindler are at your disposal around the clock for such services.

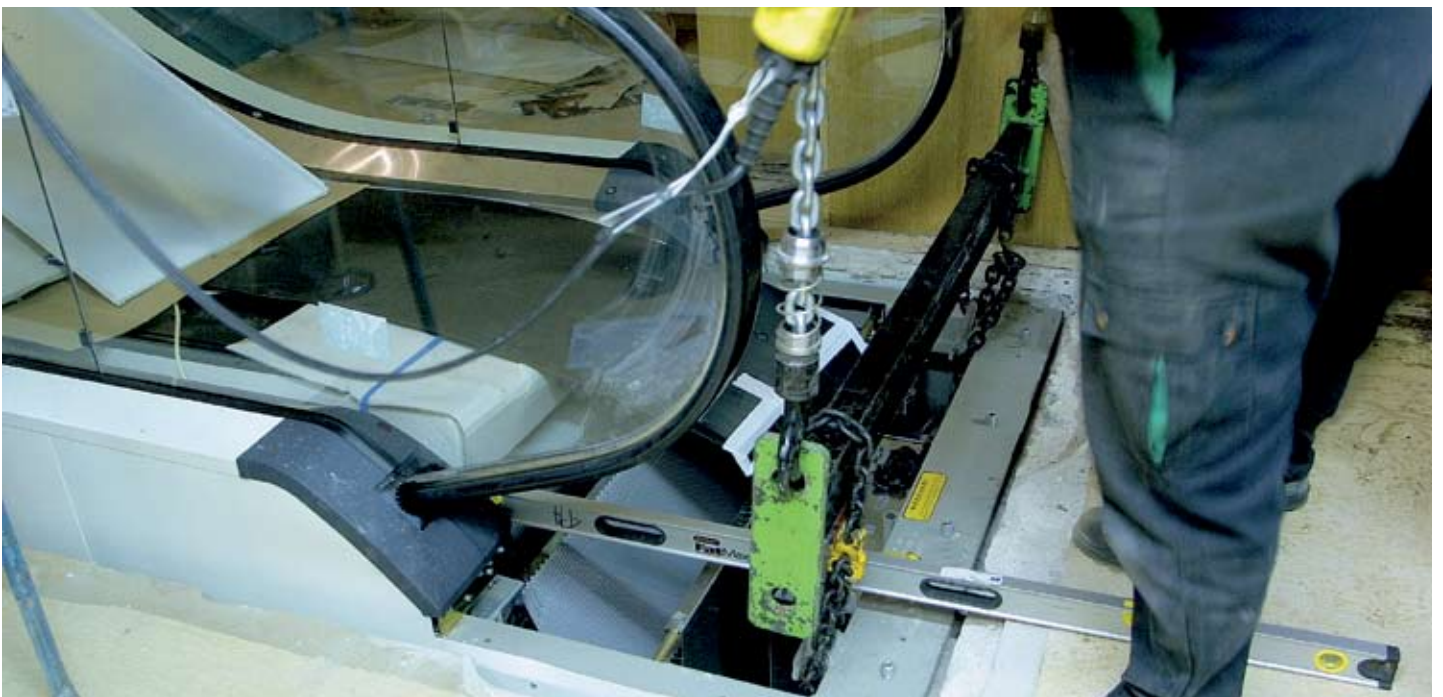

Interactive configuration with SchindlerDraw

For project-specific configurations we recommend SchindlerDraw, the interactive online configuration tool available at www.schindler.com.

With SchindlerDraw you can create and download project-specific *.dxf and *.dwg files as well as neutral specification texts to suit the data you have. The projects remain stored in your personal project center, where they may also be processed at a later stage.

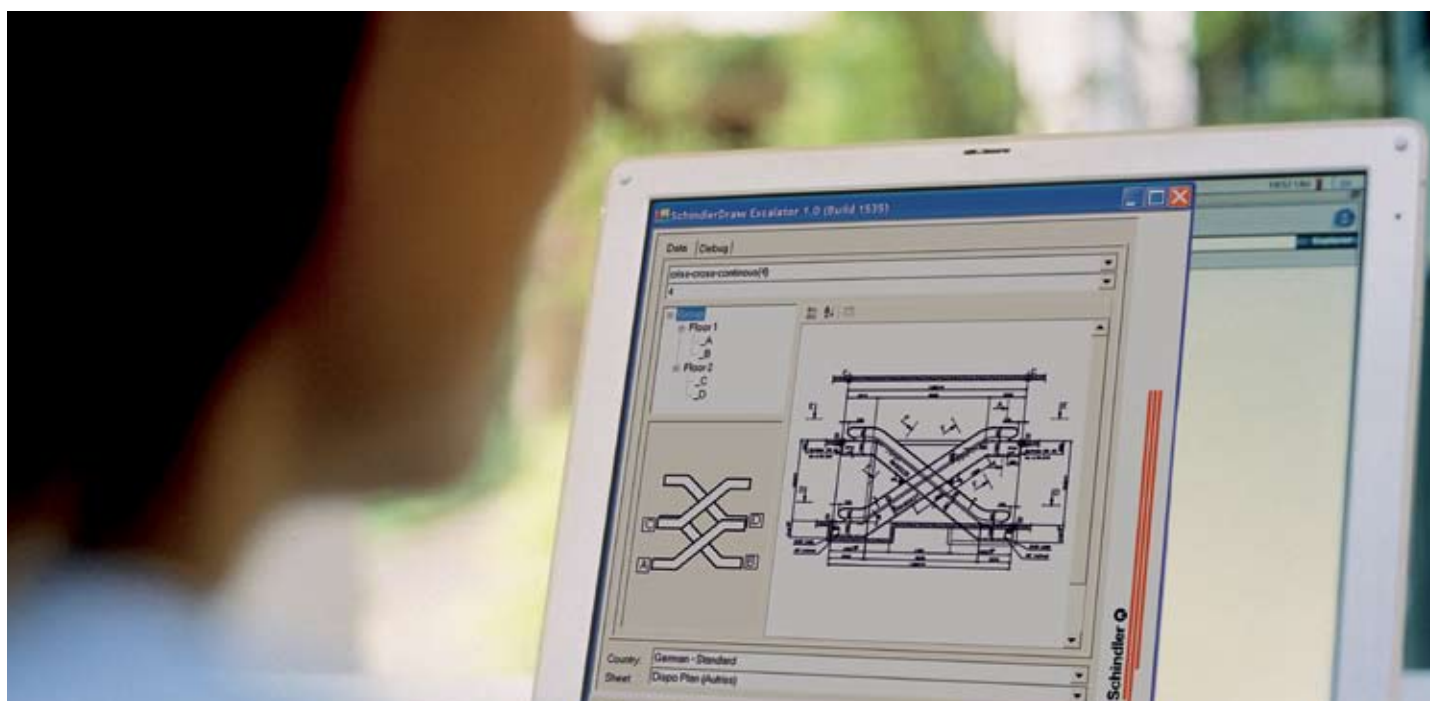

Key points for the planning process

Checklist

Approval of the layout drawing

- Pit dimensions
- Rise
- Support distance and dimensions
- Electrical feed lines
- Sprinkler connections, if necessary
- Phone connection for remote monitoring
- Water drain for outdoor installation

Services to be provided by the customer

- Masonry, scaffolding and cutting work
- Structural supports for the escalator or moving walk supports
- Protective railings for the upper floor opening, if necessary
- Power supply to the escalator or moving walk main switch
- Phone line for remote monitoring
- Erection of scaffolding and barriers, provision of openings, removal of doors and portals (if necessary to bring the unit inside the building)
- Covering of finished floor with planking and, if necessary, support of floors for transportation and suspension of the unit in the building
- Any incurred acceptance and testing fees
- Satisfactory covering of the unit to protect against damage and dirt until commissioning
- Erection of barriers to protect against unauthorized access to the unit (e.g., site barriers, warning signs)
- Protective barriers, ceiling deflectors, wedging guards (optionally supplied by Schindler)
- Cleaning of the unit to remove dirt accumulated during construction, if necessary
- Water drain, oil separators per building codes

And remember, if you have any questions, our experts are always available to help you!

We are always close by.

Please contact one of the following addresses:

Brunei

Schindler Liftec Sdn. Bhd.
Unit B8, 1st Floor, Kompleks Setia Kenangan
Kg. Kiulap, Mukim Gadong
Bandar Seri Begawan BE 1518
Negara Brunei Darussalam
Telephone + 673 2 236 515
 + 673 2 236 516
Fax + 673 2 236 470
info@bn.schindler.com

Cambodia

Jardine Schindler (Cambodia) Ltd.
#183FEo, Mao Tse Toung Blvd, Sangkat Toul Svay Prey I
Khan Chamkamorn, Phnom Penh, Cambodia
Telephone + 855 23 223 075
Fax + 855 23 223 076
info@kh.schindler.com

Hong Kong

Schindler Lifts (Hong Kong) Ltd.
29th Floor, Devon House, Taikoo Place, 979 King's Road
Quarry Bay, Hong Kong
Telephone + 852 2516 8168
Fax + 852 2516 6026
info@hk.schindler.com

Indonesia

P.T. Berca Schindler Lifts
Menara Rajawali 5th Fl Podium
Jl. Mega Kuningan Lot 5.1
Kawasan Mega Kuningan, Jakarta 12950, Indonesia
Telephone + 62 21 576 1476
 + 62 21 576 1582
 + 62 21 576 3338
Fax + 62 21 576 1844
info@id.schindler.com

Korea

Schindler Elevator Co., Ltd. (Korea)
No. 437-23, Joong-Ang Building
Bangbae-2dong, Seocho-Gu, Seoul, Korea
Telephone + 82 2 3470 2500
Fax + 82 2 3470 2601
info@kr.schindler.com

Macau

Jardine Schindler Lifts (Macao) Ltd.
No. 180 Alameda Dr. Carlos D Assumpcao
EFD. Tong Nam Ah Central Comercio, 10-andar-P, Macau
Telephone + 853 2883 7273
Fax + 853 2883 7264
info@hk.schindler.com

Malaysia

Antah Schindler Sdn Bhd (3837-H)
7th & 8th Floor, Bangunan TH Uptown 3
No. 3 Jalan SS 21/39, Damansara Uptown
47400 Petaling Jaya, Selangor D Ehsan, Malaysia
Telephone + 60 3 7725 1818
Fax + 60 3 7725 1181
info@my.schindler.com

Myanmar

Myanmar Jardine Schindler Ltd.
No. 15(F), ThanTa Man Street, Dagon Township,
Yangon, Myanmar
Telephone + 95 1 228 376
Fax + 95 1 226 930

Philippines

Jardine Schindler Elevator Corporation
2307 Pasong Tamo Extension, Makati City 1231, Philippines
Telephone + 63 2 843 1402
Fax + 63 2 843 1419
info@ph.schindler.com

Singapore

Schindler Lifts (Singapore) Pte. Ltd.
1 Kaki Bukit Place, Singapore 416179
Telephone + 65 6748 8611
Fax + 65 6846 2212
info@sg.schindler.com

Taiwan

Jardine Schindler Lifts Ltd.
9th Floor, 35 Kwang Fu South Road
Taipei 105, Taiwan, R.O.C.
Telephone + 886 2 2528 6626
Fax + 886 2 2528 6656
info@tw.schindler.com

Thailand

Jardine Schindler (Thai) Ltd.
20th Floor, Times Square Building
246 Sukhumvit Road, Klongtoey, Bangkok 10110, Thailand
Telephone + 66 2 685 1600
Fax + 66 2 685 1601
info@th.schindler.com

Vietnam

Schindler Vietnam Ltd.
5/F, Saigon Centre, 65 Le Loi Street, District 1
HCMC, Vietnam
Telephone + 84 8 821 3383
 + 84 8 821 3384
Fax + 84 8 821 3382
info@vn.schindler.com

Or visit our website:

www.jardineschindler.com

Disclaimer

The specifications, options and colors expressed within this brochure are indicative only and are subject to change without notice. They are not intended to, and do not, constitute an offer on the part of the Jardine Schindler Group.